

User Manual

TS2000 Pro Series Tripod Turnstile

Version: 1.0

Date: September 2018

Contents

1. Technical Specifications	1
2. Arm installation and Equipment Testing.....	2
2.1 Arm installation	2
2.2 Power-on test before installation	2
3. Equipment Installation	3
3.1 Installation conditions.....	3
3.2 Cabling	4
3.3 Installation	5
4. Cable Diagram	6
4.1 Function descriptions of the turnstile control board.....	6
4.2 DIP K1 switch configuration	8
5. Equipment Precautions and Maintenance	9
5.1 Precautions	9
5.2 Maintenance.....	10
6. Troubleshooting	11
Attachment 1 Default Factory Settings.....	12
Attachment 2 Connection Diagram of Control board and Access Control Panel	13

TS2000 Pro: Tripod Turnstile.

TS2011 Pro: Tripod Turnstile with Controller and RFID Reader.

TS2022 Pro: Tripod Turnstile with Controller and Fingerprint Reader with RFID function.

Please read this document carefully before installation and using the device.

1. Technical Specifications

Input Voltage	AC 100~120V /200~240V, 50Hz /60Hz	Max. Tolerance of Arms	Center: 80 kg End: 40 kg
Rated Power	60 W	Ingress Protection Degree	IP54
Operating Environment	Indoor and Outdoor (shelter)	Arm Length (mm)	500
Operating Temperature	-28°C ~ 60°C	Net Weight	46kg
Operating Humidity	5% ~ 85%	Gross Weight	54kg
Flow Rate	Max 30 passages / minute	Dimension(mm) Figure 1-1	L = 1110, W = 280, H =990
Input Control Signal	Dry contact	Package Size (mm)	L = 1175, W = 370, H = 1070

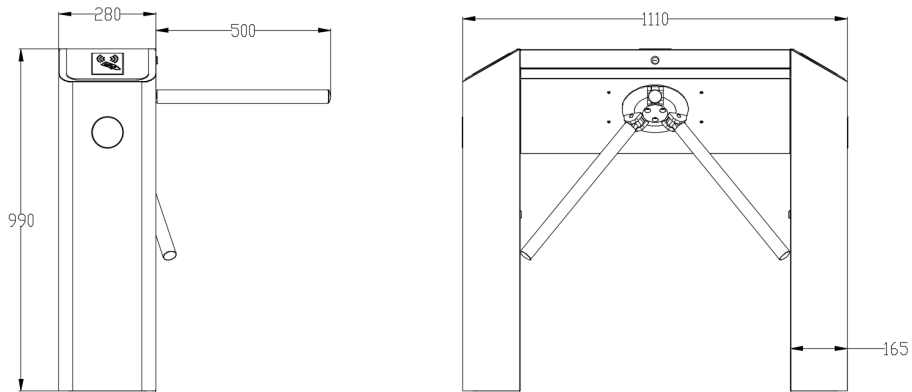

Figure 1-1

2. Arm installation and Equipment Testing

2.1 Arm installation

In order to prevent the arm from damaging during transportation, the arm will not be initially installed to the devices.

Installation procedure

Put the arm into the hole of cabinet; make sure the screw holes match with mechanism core, then tighten 3 hex screws, as shown in Figure 2-1.

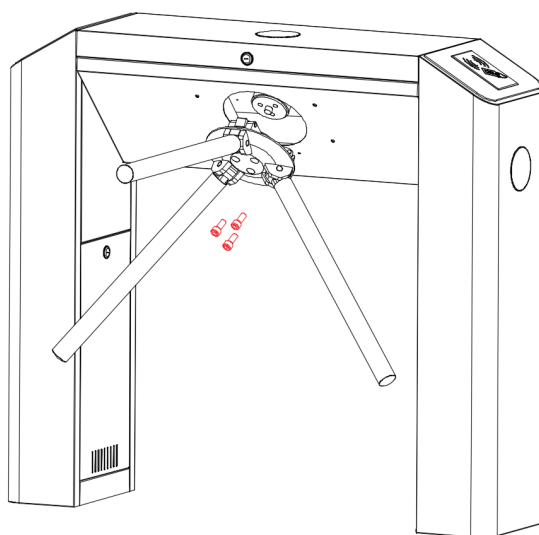

Figure 2-1

2.2 Power-on test before installation

1. Please make sure that the power requirements are strictly met to avoid permanent damage to the unit. Input voltage: AC 100~120V /200~240V.

Note: The tripod turnstile must be connected to the ground (earth).

2. Power on and wait 30s for the tripod turnstile to finish the self-check program.
3. Lift the arms manually, as shown in Figure 2-2.
4. Check whether the tripod turnstile and the LED indicators work properly.

If there is any problem, please contact the supplier.

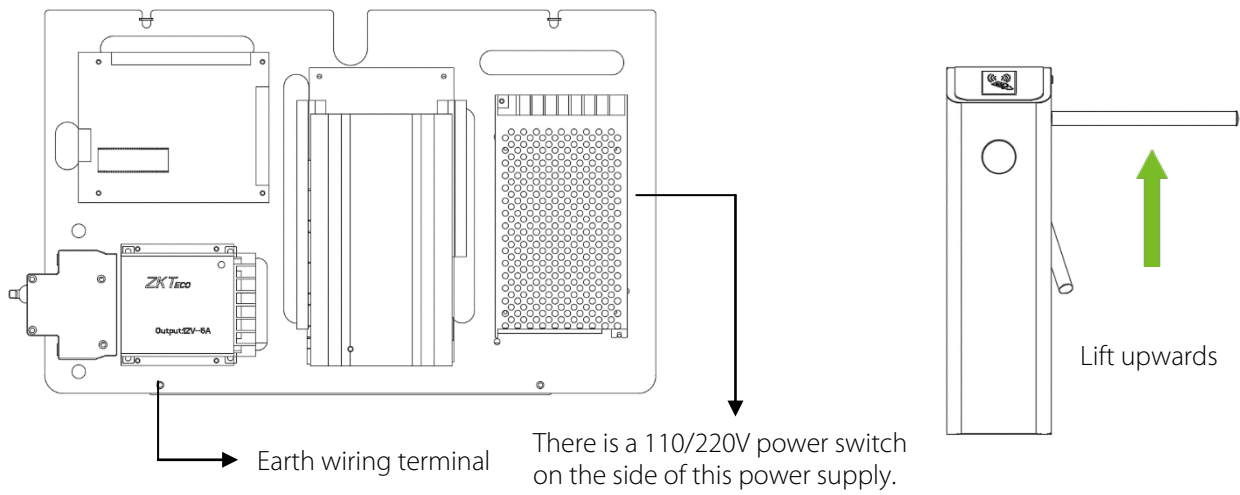

Figure 2-2

3. Equipment Installation

3.1 Installation conditions

The equipment must be installed on concrete ground, ensuring that expansion bolts can be secured firmly. You are suggested to install an assistant framework or fence to form a passageway, as shown in Figure 3-1.

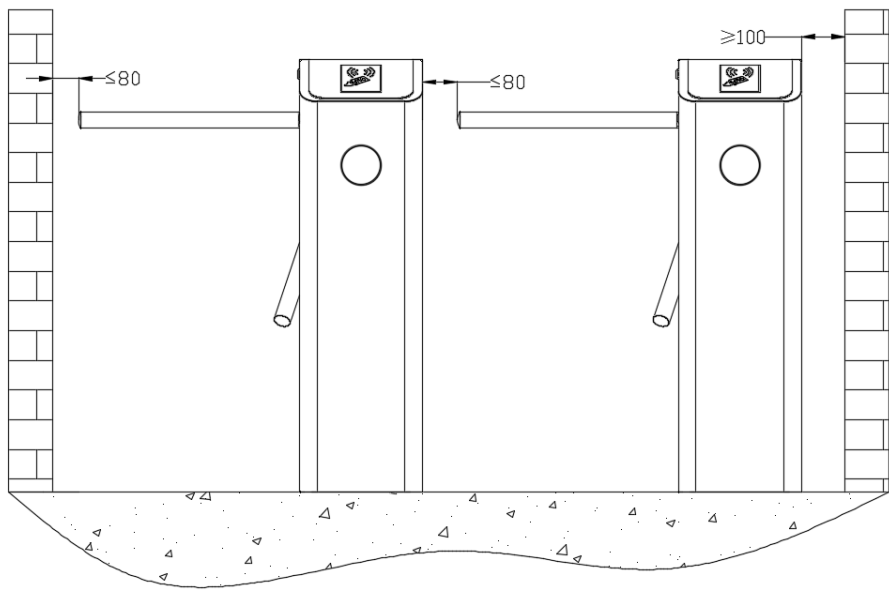

Figure 3-1

Notes:

1. When installing the tripod turnstile against the wall, please reserve a distance of at least 100 mm in order to open the cover for future adjustment and maintenance.
2. The spare space from the end of the arm shall not be greater than 80 mm (see Figure 3-1).
3. You are also recommended to set a warning line for card swiping (see Figure 3-2). The warning line prompts users to swipe cards in a particular area, which would greatly reduce the probability of equipment failure caused by improper operations.

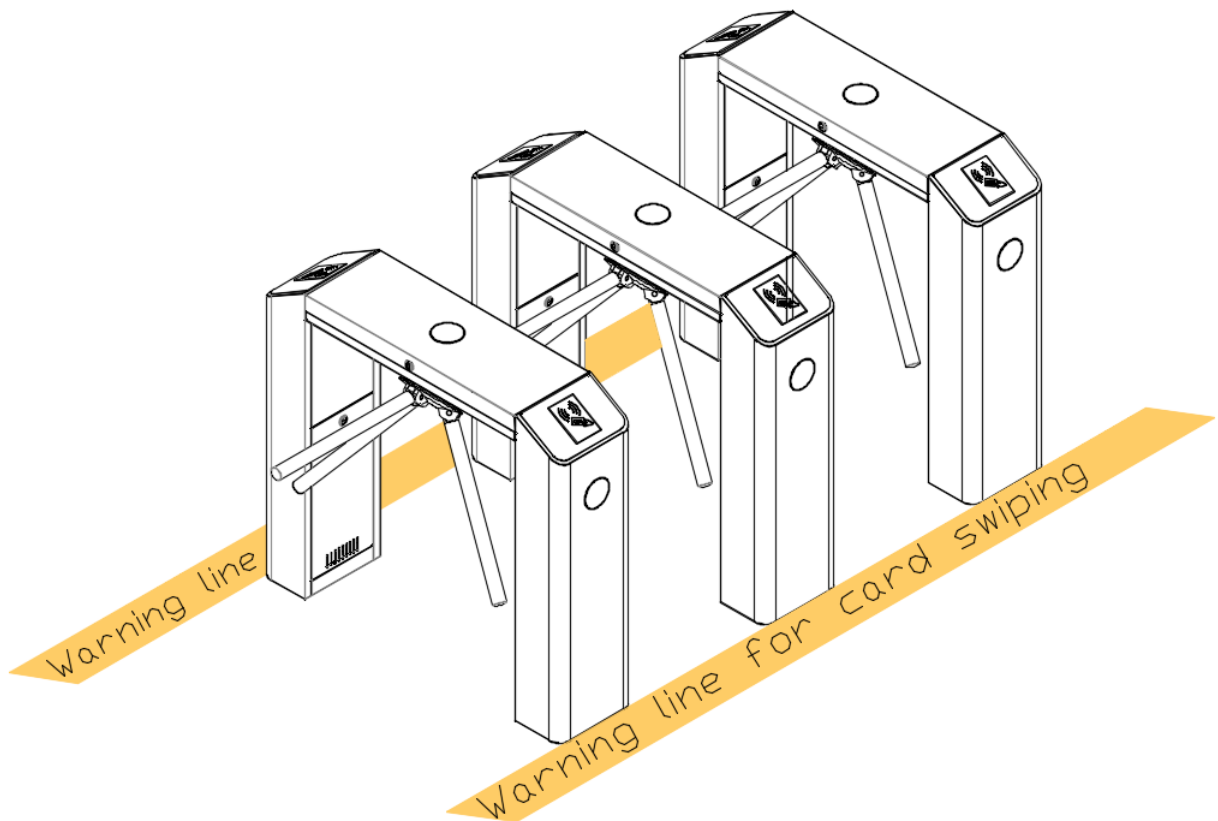

Figure 3-2

3.2 Cabling

There are inlets in the bottom plate for cabling, as shown in Figure 3-3. Units of all data is millimeter. Power supply and communication wire should go through the inlet.

Warning: The tripod turnstile must be connected to the ground (earth); there is wiring interface near the power switch.

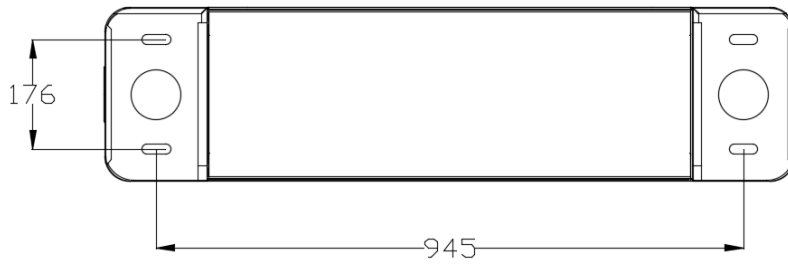

Figure 3-3

3.3 Installation

1. Drill holes.

Drill holes according to the locations of holes as shown in Figure 3-3.

2. Fix the mounting plate to its original position.

3. Place the mounting plate properly, then apply screw securing glue on the surface and threads of the expansion bolts, install four expansion bolts to secure the mounting plate, and use a horizontal ruler to test the levelness of the mounting plate. If the mounting plate is not levelled, adjust it with the gaskets provided. Note that all the four expansion bolts must be installed properly, as shown in Figure 3-4.

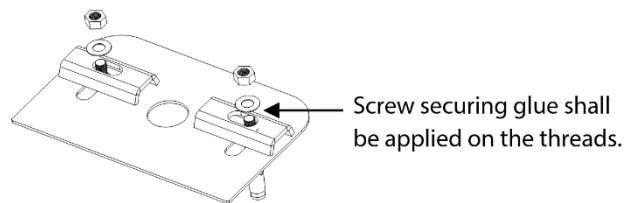

Figure 3-4

4. Install the turnstile on the mounting plate and tighten the screws. Apply screw securing glue before using and putting gaskets on the screws to adjust the direction of the turnstile. If the tripod turnstile is not levelled, please move gaskets to adjust, as shown in Figure 3-5.

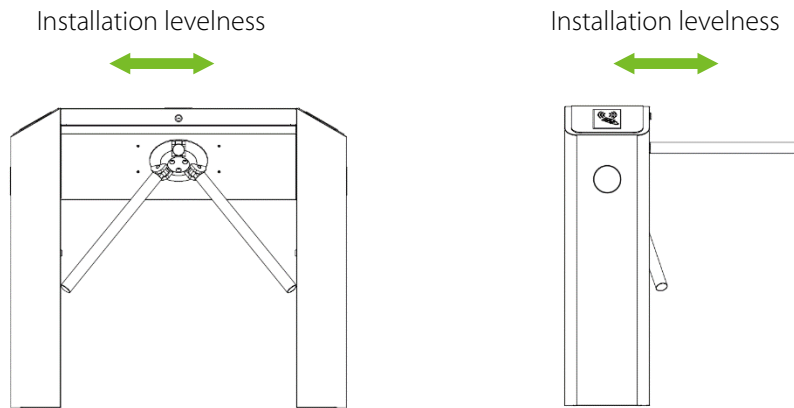

Figure 3-5

4. Cable Diagram

4.1 Function descriptions of the turnstile control board

If you are using TS1011 Pro or TS1022 Pro, all connections between access control and turnstile control boards are completed in advance. You just need to plug in the communication cable to access the controller and do the settings.

If you are using TS1000 Pro, you need to connect the access control system with the control board. Please read the instructions in this chapter carefully.

Warning: The trigger time of third-party access control system lock relay should be 1 second or less than 1 second.

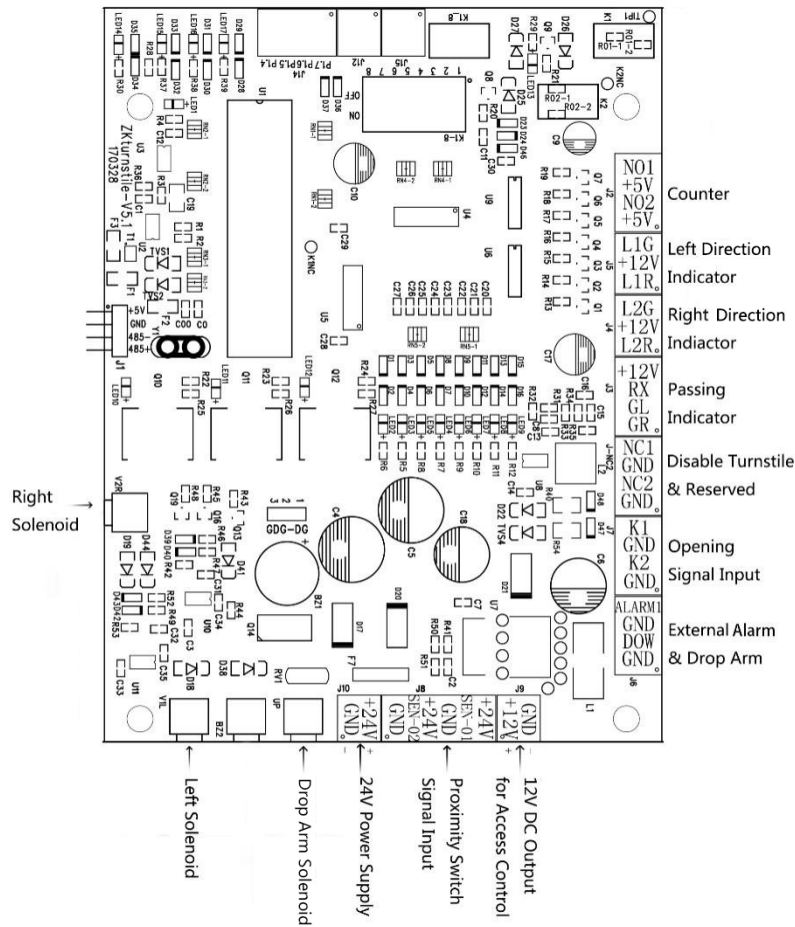

Figure 4-1

Descriptions:

J2 Counter: To connect the device with a LED screen and display the number of passages which is generated by each push of tripod arms. Each valid access counts one time.

J5 (Right) & J4 (Left) Indicator: To connect a LED screen and indicate whether this person is granted access.

J3 Indicator (top): To connect a LED screen and indicate if the user verification is successful and whether the person is granted access.

J-NC2 Disabled Turnstile: Short-circuit NC1 and GND to disable the turnstile, which means that the turnstile is locked by force.

J7 Opening Signal Input: To receive relay signals and open the turnstile. Short-circuit K1 and GND to allow passing on the left; short-circuit K2 and GND to allow passing on the right.

J6 External Alarm: Short-circuit ALARM1 and GND to disable (i.e. lock) the turnstile. The alarm will be activated in case of emergencies.

J6 Drop Arm: Short-circuit DOW and GND to drop the arm by force in case of fires or other emergencies.

J8 Proximity Switch Signal Input: Input position signal of the arm.

J9 12V Power Supply for Access control: the control board directly provides access control service with 12V power (maximum support 3A).

V1L Left Solenoid, V2R Right Solenoid & Drop Arm Solenoid: Control the passage and arm dropping.

4.2 DIP K1 switch configuration

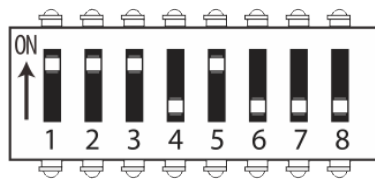

Figure 4-2

Pin	1	2	3	4	5	6	7	8
Function Setting	Opening Duration			Direction Indicator		Continue Passing Function		Alarm
Default	1	1	1	0	1	0	0	0

4.2.1 Setting the turnstile opening duration

Opening duration refers to the period of time from opening to closing once the turnstile receives an opening signal. In the DIP switch, number 1, 2, and 3 are used for duration settings. It can be set to different values from 5s to 60s according to the following chart.

Bit Setting	Duration	Bit Setting	Duration
111	5s	011	30s
110	10s	010	40s
101	15s	001	50s
100	20s	000	60s

Note: The turnstile's opening duration is set to 5s by default.

4.2.2 Direction indicator

It is to indicate whether people can pass through the gate. The green arrow means passing is allowed while the red cross "X" means that passing is prohibited. The indicator status can be set with number 4 and 5 in the DIP switch.

The descriptions of the bit settings are as follows:

11 = One-way traffic; left passing is allowed.

10 = One-way traffic; right passing is allowed.

01 = Passing is allowed in both directions.

4.2.3 Continue passing function

With the "Continue Passing" function, the turnstile could remember at most 20 swipes of one card at one time and allows up to 20 people to pass so they don't have to swipe card each time. This function can be enabled or disabled with number 6 in the DIP switch. The descriptions of the bit settings are as follows:

In the DIP switch, number 6 is used to enabled or disabled the **Continue Passing Function**; number 7 is used to set the initial value of **Continue Passing Function**.

number 6	number 7	Function	Opening Duration
0	disabled	Disabled Continue Passing Function	Please consult 4.2.1 Setting the Turnstile Opening Duration .
1	1	Enabled Continue Passing Function	The initial value is 16s, and the Opening Duration = $16 + (N - 1) * 6$.
	0		The initial value is 8s, and the Opening Duration = $8 + (N - 1) * 6$.

5. Equipment Precautions and Maintenance

5.1 Precautions

1. It is recommended to purchase additional accessories to use the product outdoors.
 - (1) You may install cooling fans for the equipment if the working temperature is often above 50 °C.
 - (2) The device is rated IP54 waterproof under proper installation. However, its ability to stand in extreme weather conditions, such as typhoon, is not guaranteed.
 - (3) If the temperature is around or below -30°C, you are recommended to install a heating plate for the equipment. You might need to turn the power on multiple times to let the device automatically heat up through the self-check program.
 - (4) The service life of this equipment may be shortened if it works outdoors in coastal areas or a region prone to acid rain.
2. If the power and signal cables are connected properly, this equipment can be immersed under water at a depth of 250 mm, but it must not be powered on when it is immersed in water.
3. It is highly recommended to set a warning card-swiping line to remind passers-by to correctly swipe cards at a reasonable distance from the device to prevent passers-by from being squeezed.

4. It is recommended to place a warning sign at a conspicuous position, and prompt: **"Please swipe your card outside the warning line and pass in order. Thank you!"**

The maximum stress tolerance of the tripod turnstile's arms

Please note that the maximum tolerance at the center and the ends of the arm is 80kg and 40kg, respectively (See Figure 5-1). When the impact force on the tripod turnstile reaches the designed limit, the arms will break down first to ensure that the body of the equipment is not damaged and the passer-by is not injured.

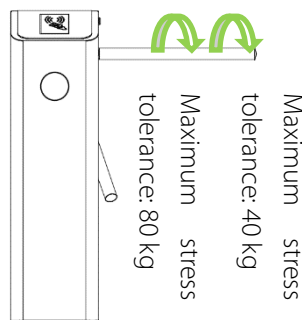

Figure 5-1

In case of emergencies

This equipment is designed to drop the arms automatically if there is power failure make sure the passengers through the turnstile free. Also, there is an interface on the turnstile control board connecting with an emergency switch (J6 Drop Arm) which keeps the tripod turnstile open in case of emergencies. Please lift the arms manually after at least 6 seconds after power restoration.

5.2 Maintenance

Forming maintenance consciousness

The tripod turnstile needs to be maintained regularly and repaired once it is damaged. It is recommended placing warning signs at conspicuous positions for alerting every passersby to pass carefully and in good order. Reasonable maintenance consciousness helps to guarantee long-term usage of the tripod turnstile.

Regular maintenance

Cleaning and protection liquid dedicated for stainless steel are recommended to wipe the outer shell of the equipment regularly. The tripod turnstile used outdoors or in an environment with lots of dust must be maintained at least once a year, for example, clean up the dust and add appropriate lubricating oil to the disk wheel. Please note that regular maintenance should only be performed after power-off, as shown in Figure5-2.

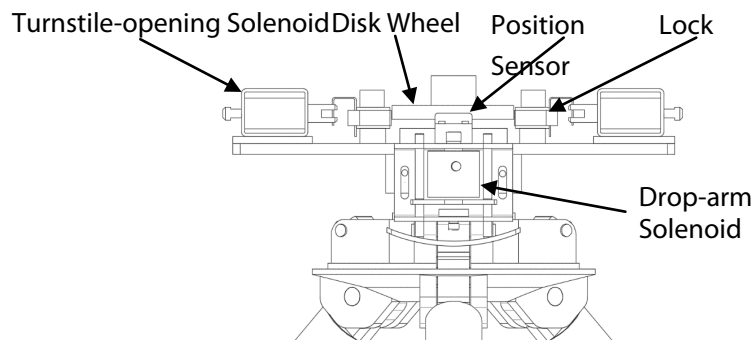

Figure 5-2

6. Troubleshooting

Symptom	Troubleshooting
The indicator is not lit when the equipment is powered on.	It may be caused by the power supply or circuit. Check whether the connection cable and power cable are damaged, or whether the wiring is loosed.
The arms of the tripod turnstile cannot be lifted manually after the equipment is powered on.	It may be caused by the problem of related components or drop-arm solenoid. Check whether the drop-arm solenoid is operating, and check the working status of the solenoid, as shown in Figure 5-2.
The tripod turnstile does not grant an access after successful authentication.	It may be caused by lack of permission or a circuit problem. <ol style="list-style-type: none"> 1. Check whether the user has the permission to pass. 2. Use a multimeter to check whether the NO and COM ports of the access control system have a relay signal output. 3. Short-circuit the ports "K1, GND" and "K2, GND"; if the turnstile is successfully opened, please check access controller.
The turnstile allows people to continuously passing one-way side.	<ol style="list-style-type: none"> 1. Check the turnstile-opening solenoid. 2. Check if the access controller "Lock driving duration" is set to 1s. 3. Check whether the turnstile-opening solenoid is operating and check whether something is stuck at the turnstile-opening solenoid, as shown in Figure 5-2.

Attachment 1 Default Factory Settings

No.	Function	Default
1	Lock Driving Duration	5s
2	Door Sensor	None
3	Verification Interval	1s
4	Controller Communication	TCP/IP: 192.168.1.201
5	Turnstile Opening Duration	5s
6	Passing Direction Indicator	Passing is allowed in both directions
7	Continue Passing Function	Disabled
8	Alarm Function	Disabled

Note: The Lock Driving Duration is 5 seconds by default. Please set it to 1 second. Do not connect an electrically charged objects to any ports of Opening Signal Input, otherwise it will damage the control board.

Attachment 2 Connection Diagram of Control board and Access Control Panel

Panel

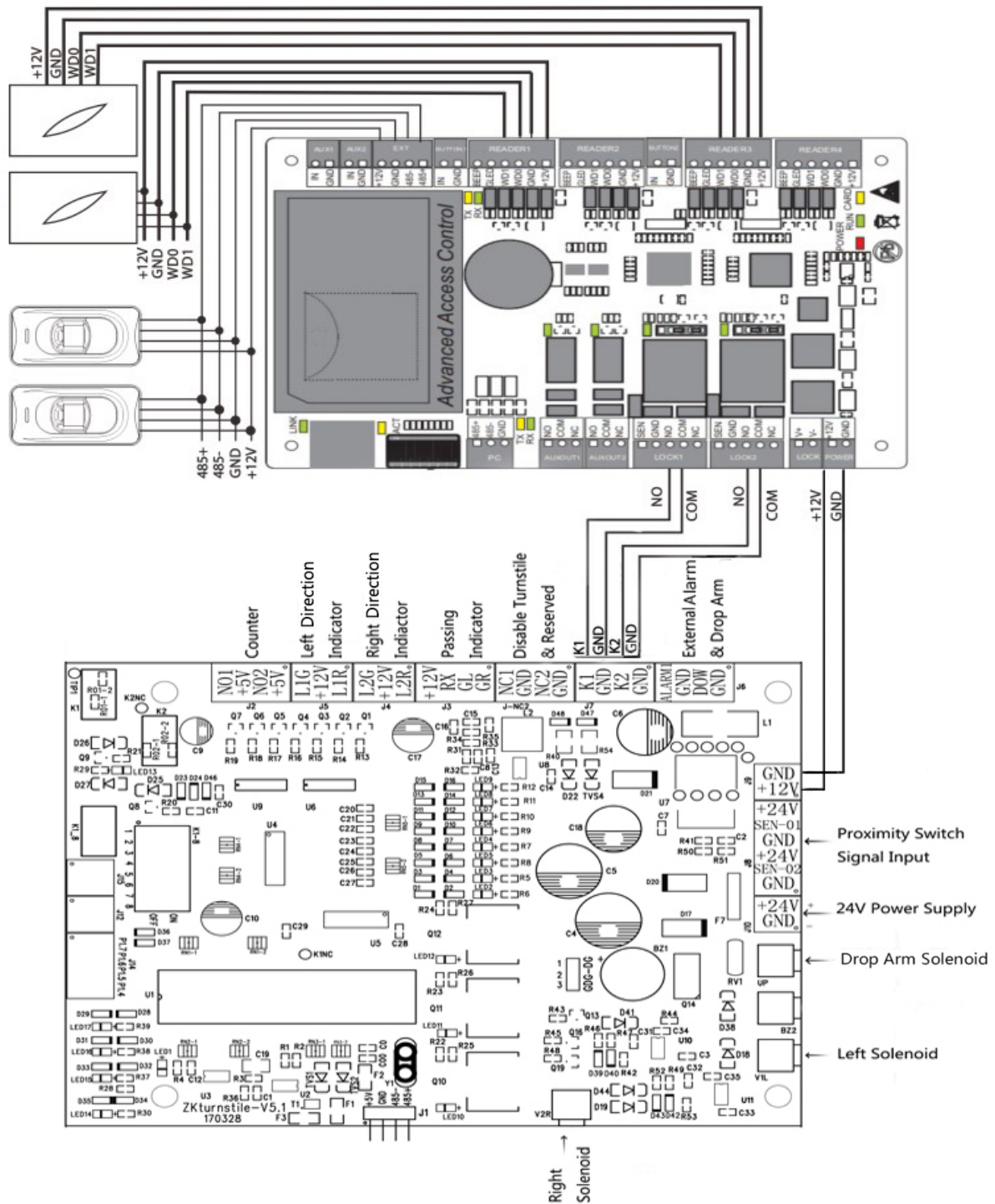

Warning: This is a class A product. In a domestic environment, this product may cause radio interference so that the user may have to take adequate additional measures.

ZK Building, Wuhe Road, Gangtou, Bantian, Buji Town,
Longgang District, Shenzhen China 518129

Tel: +86 755-89602345

Fax: +86 755-89602394

www.zkteco.com

